



**FIRE RATED
DOOR**



 **Octopus™**
FIRE DOOR

Front & Internal Elevation Of Doorset

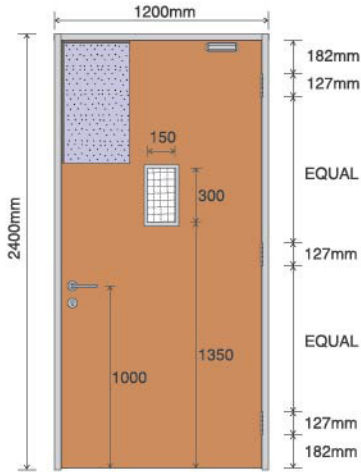

Vertical Section Of Doorset

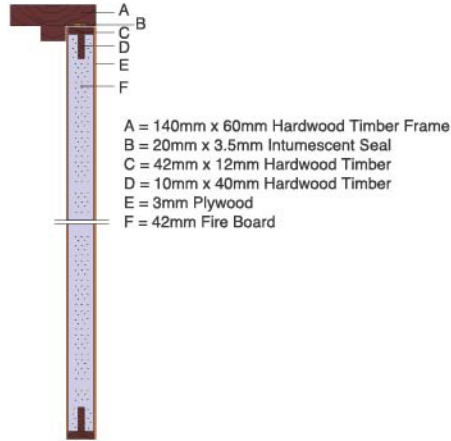

Profile Of Timber Frame
Model : Argus

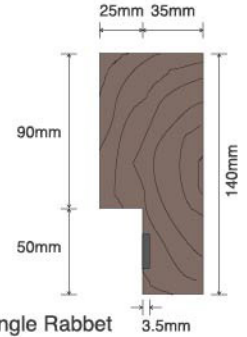

Double Rabbet 3.5mm

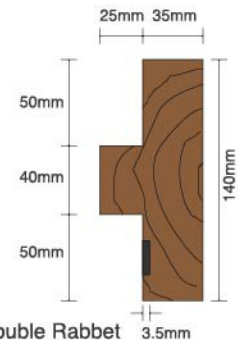

Front & Internal Elevation Of Doorset

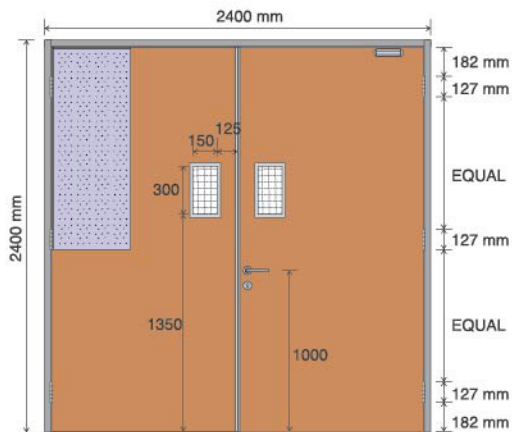

Horizontal Section Of Doorset

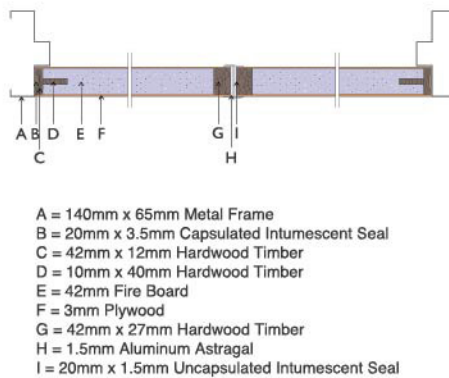

Profile Of Aluminum Astragal

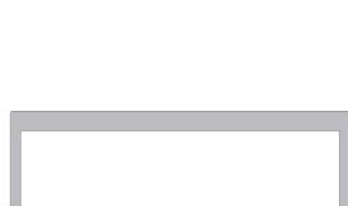

Profile Of Metal Frame
Model : Casper

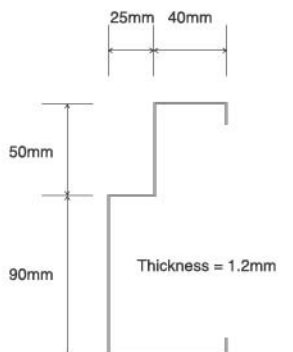
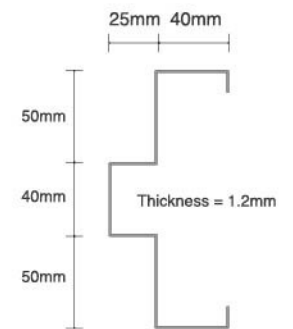

2 HOURS FIRE RATED DOORSET

Front & Internal Elevation Of Doorset
Model : Vulgaris

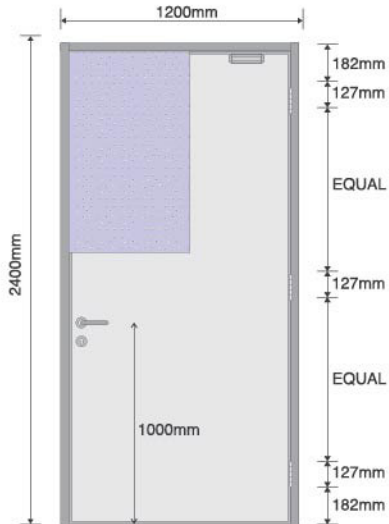

Vertical Section Of Doorset
Model : Vulgaris

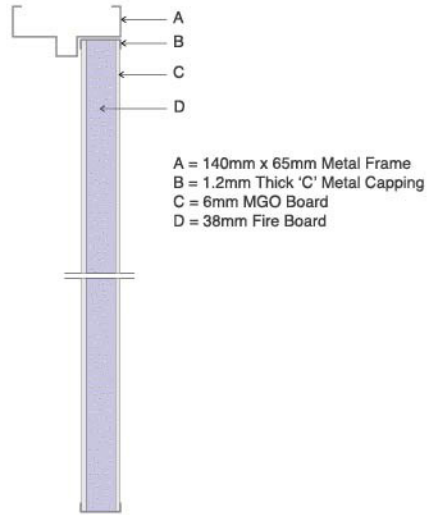

Profile Of Metal Frame
Model : Vulgaris

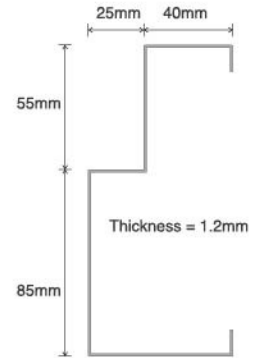

Front & Internal Elevation Of Doorset
Model : Vulgaris

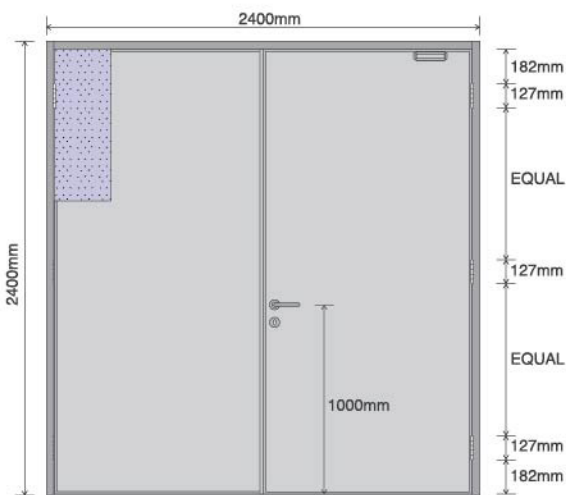

Horizontal Section Of Doorset
Model : Vulgaris

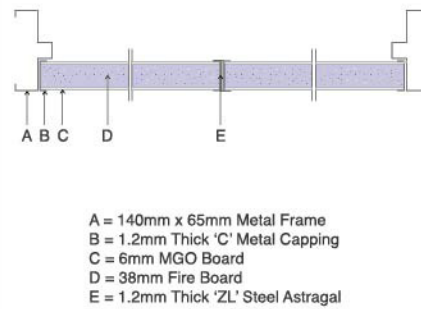

Profile Of Metal Frame
Model : Vulgaris

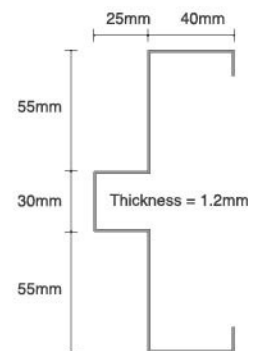

Lever Handle

KS 4201 001

Material : Stainless Steel SUS304



KS 4201 002

Material : Stainless Steel SUS304



KS 4201 003

Material : Stainless Steel SUS304



KS 4201 004 (optional)

Material : Stainless Steel SUS304



KS 4201 011 (optional)

Material : Stainless Steel SUS304



Euro Profile Cylinder



T19S65 THUMBTURN

■ Mortise Lock

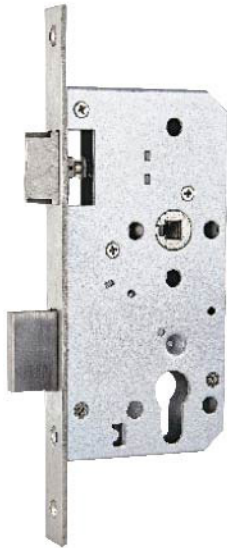

72 SERIES

■ Door Closer



72 V

■ Door Selector

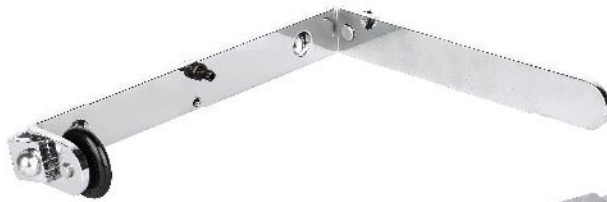

DC-9402



DC-9403

■ Autobolt

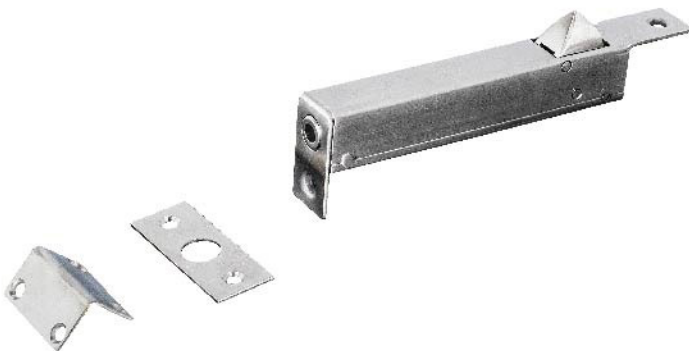

DA-9317

■ Hinges



DA-9315
(127mm x 89mm x 2.5mm)

OCTOPUS Fire Doors comply with stringent UBBL building regulation for fire resistance for safety and has tested to MS 1073: Part3: 1996 (Amd I : 2003). Our product is listed under SIRIM's Product Certification Unit and carries the MS mark.

OCTOPUS Firedoors is an important element to any home, office, building and facilities. When people purchase doors, they often look at features such as style, design, cost and quality. However, a feature that is commonly overlooked is whether it is fireproof or not. We supply an amazing selection of firedoors that are stylish, excellent quality, secure, durable, and reliable and fire resistance. OCTOPUS Firedoors is an essential element are a great way to limit the risk of passive fire during a fire outbreak. It gives you a peace of mind that risk of the fire spreading is heavily reduced therefore keeping you, your family and your possessions safe.

OCTOPUS Firedoors are manufactured with various core specifications to meet the standards and requirements of the intended application. It features a solid core specification, containing a high density extruded fireboard panel. The main inner core of our doors is made of extruded high density fireboard thus, providing sound acoustic properties.

DOOR STANDARDS: • MS 1073: PART 3: 1996 (Amd I : 2003)

